

# USER MANUAL

## DIGITAL - SERVO CONTROLLED VOLTAGE STABILIZER



SUVIK provides customers solutions with technical support. Users may contact the Customer service department.

While every precaution has been taken to ensure accuracy and completeness in this manual, SUVIK assumes no responsibility and disclaims all liability for damages resulting from use of this information or for any errors or omissions.

SUVIK pursues a policy of continuous product development and reserves the right to change the equipment design without notice. The contents in this document are subject to change without notice

## TABLE OF CONTENTS

1.0	<u>IMPORTANT SAFETY WARNING</u> .....	4
1.1	TRANSPORT .....	4
1.2	SETUP .....	4
1.3	INSTALLATION .....	4
1.4	OPERATION .....	4
1.5	MAINTENANCE, SERVICING AND FAULTS .....	4
2.0	<u>INTRODUCTION</u> .....	5
2.1	THE OUTSTANDING FEATURES OF THESE REGULATORS ARE BRIEFLY SHOWN BELOW .....	5
2.2	WAVEFORM OF INPUT VOLTAGE AND OUTPUT VOLTAGE .....	6
2.3	DIFFERENT APPLICATION OF SERVO CONTROLLED VOLTAGE STABILIZER .....	6
3.0	<u>PRINCIPLE OPERATION</u> .....	7
4.0	<u>OPERATIONS</u> .....	8
4.1	FRONT PANEL SWITCH OPERATION .....	8
4.2	PARAMETER DISPLAY .....	9
4.3	FAULT DISPLAY .....	9
4.4	USER PARAMETER CONFIGURATION .....	10
5.0	<u>TROUBLE SHOOTING</u> .....	11
6.0	<u>CONNECTION</u> .....	13
7.0	<u>WARRANTY CERTIFICATE</u> .....	14

## **1.0 IMPORTANT SAFETY WARNING**

*As dangerous voltages are present within the SCVS, only SUVIK technician is permitted to open it. Failure to observe this could result in electric shock risk and invalidation of any implied warranty.*

### **1.1 TRANSPORT**

Please transport the SCVS only in the original packaging (to protect against shock and Impact).

### **1.2 SETUP**

- Do not install the SCVS system near water or in damp environments.
- Do not install the SCVS system where it would be exposed to direct sunlight or near heat source.
- Do not block off ventilation openings in the SCVS system's housing.

### **1.3 INSTALLATION**

*This manual contains information concerning the installation and operation of the Digital SCVS  
All relevant parts of the manual should be read prior to commencing the installation.*

*Before installation, please inspect the unit. Be sure that nothing inside the package is damaged. Please keep the original package in a safe place for future use*

- Ensure not to connect equipment which leads system to overload.
- Place cables in such a way that no one can step on or trip over them.
- For sock proof operation always connect proper earthing to system before making it on.
- Ensure that input to the SCVS & load cable are shock proof.
- The SCVS must be serviced by an authorized representative of SUVIK. Failure to do so could result in personnel safety risk, equipment malfunction and invalidation of warranty.
- Digital SCVS has been designed for Commercial/Industrial use only, and is not recommended for use in life support applications.
- Before energizing the system ensure input, output and earth connections are proper.

### **1.4 OPERATION**

- Do not disconnect the mains cable on the SCVS system during operation.
- Before disconnection the SCVS ensure load is safely shutdown.
- Ensure that no fluids or other foreign objects can enter the SCVS system.

### **1.5 MAINTENANCE, SERVICING AND FAULTS**

- The SCVS system operates with hazardous voltages. Repairs may be carried out only by qualified maintenance personnel.
- Before carrying out any kind of servicing and/or maintenance, disconnect the input and verify That no current is present and no hazardous voltage exists in the system.
- Do not dismantle the SCVS system.

## **2.0 INTRODUCTION**

A typical voltage stabilizer is able to respond to changes in the voltage level on the input line. These changes are called sags (voltage drops) and surges (voltage peaks). Sags might be due to undersized distribution lines, connection of large loads to the network, ground faults, etc.

Surges might be generated by disconnection of large loads, increased voltage at the generating plant, atmospheric events, etc.

The duration of such phenomena depends on their cause and is not easily predictable. Sags are generally more common especially where the distribution is not wide and efficient.

Other disturbances like spikes, transients, high frequency noise and harmonic distortion have to be treated with the addition of specific filtering systems.

The good functioning of the majority of electrical and electronic equipment depends on the supply voltage correctness and steadiness. Nowadays, many industrial and private users are subject to long-lasting fluctuations that can be inconvenient or even dangerous.

AC Voltage Regulators are used for obtaining a steady AC supply with very close tolerances from fluctuating mains. They find application in a very wide variety of fields such.

There are various types of Automatic AC Voltage Regulators to suit the different requirements of various special fields. Of these, the Micro Controller based Servo Controlled Automatic Voltage Regulator offer the maximum advantages. These include close accuracy of the output for all variations of line voltage & load current within the specified limits virtually no waveform distortion, efficiencies of over 95%.

### **2.1 THE OUTSTANDING FEATURES OF THESE REGULATORS ARE BRIEFLY SHOWN BELOW**

- Very low internal impedance.
- Fast rate of correction.
- Virtually zero waveform distortion.
- Efficiency greater than 95%.
- Wide Operating temperature range without affecting the output voltage.
- Wide frequency range from 47 to 53Hz.
- Provision of an audio visual warning at extreme voltage levels outside the controllable band. (Optional)
- Modular (Plug-in) type control circuit.

Servo Regulators being electromechanical devices cannot provide an instantaneous correction in the output voltage as shown in following waveform.

## 2.2 WAVEFORM OF INPUT VOLTAGE AND OUTPUT VOLTAGE

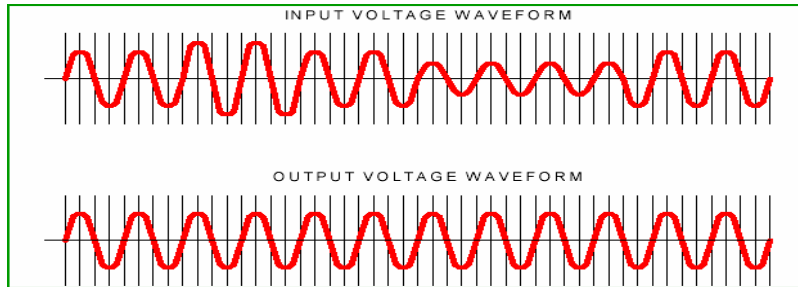

Fig-1

## 2.3 DIFFERENT APPLICATION OF SERVO CONTROLLED VOLTAGE STABILIZER

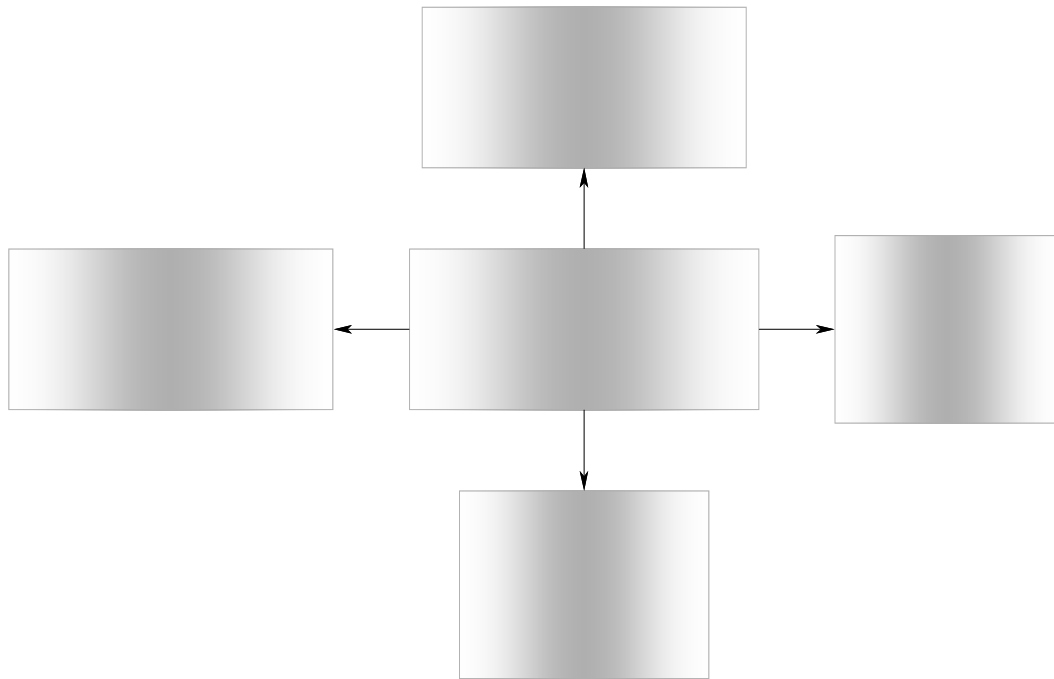

Fig-2

FOO  
-Bott  
-Pac  
-Foo  
-Anir

### 3.0 PRINCIPLE OPERATION

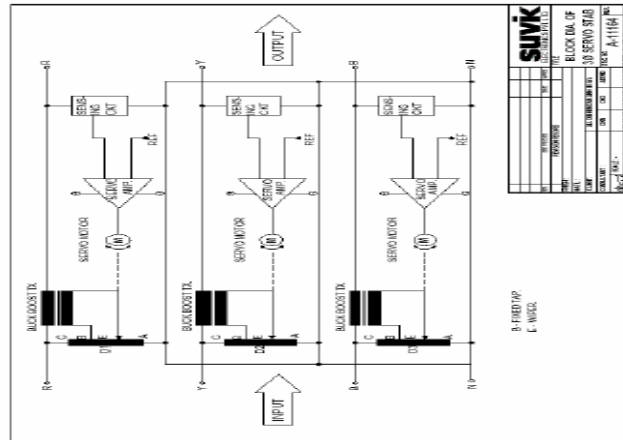

Fig-3

A block schematic diagram showing the connections of basic sub units of the regulators is given in above Figure.

The secondary winding of a double wound buck/boost control transformer is connected in series to the supply line going to the load. Its primary winding is fed with a voltage from a variable autotransformer which is connected across the input supply. The voltage induced in the secondary winding gets added to or is subtracted from the mains voltage depending upon its phase with respect to the line voltage. The induced voltage will either be in phase or out of phase by 180° with the supply voltage.

Buck or Boost is obtained depending on which side of the auto transformer the wiper contact is placed relative to the fixed tap. While the range of correction possible depends on the magnitude of the adding or subtracting voltage injected between the supply and the load by the auto-transformer. The injected voltage is maximum when the wiper contact is at the two extreme position of its excursion. In the automatic servo voltage regulators the wiper arm is coupled to a servo-motor and its positioning is affected by a solid state sensor unit which samples the output voltage and compares it with a reference voltage. If it deviates from the required value, the sensor energizes the motor to rotate the variable transformer wiper until the correct voltage is restored. This method of stabilization sampling from the output automatically compensates for any changes the load current. The servo action is exceptionally fast and the de-acceleration controlled so as to result in minimum overshoot.

The integrated controller for voltage stabilizer CONTROLS the output voltages, TRIPS under fault conditions and also DISPLAYS Input, Output voltages and load currents of the three phases on a single LCD display panel simultaneously. The fault parameters and on/off delays are user settable to configure the controller for different input ranges and easy adaptability for difficult site conditions.

## 4.0 OPERATIONS

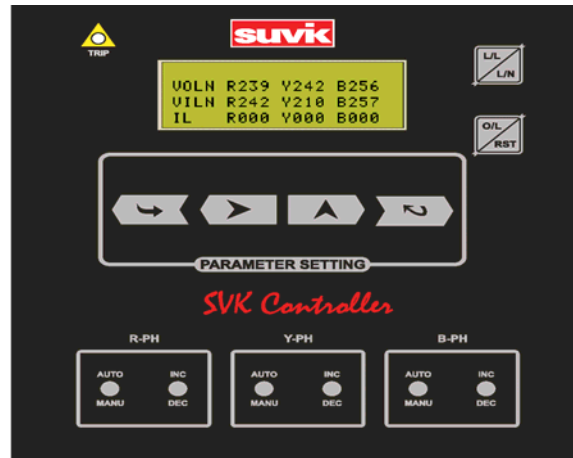

Fig-4

### 4.1 FRONT PANEL SWITCH OPERATION

Switch	Function
Enter	To Enter in the menu or Select the function from menu.
INC	Shift the cursor position right for digit value or move cursor position Down in the menu.
SHIFT	Increase digit value or move cursor position UP in the menu.
ESC	To return from current Menu.
L/L-L/N	Selections switch for Line to Line voltage or Line to neutral voltage.
O/L RST	Overload Reset Touch Key needs to be pressed for the output to turn ON when Overload tripping fault is restored. The output will remain tripped OFF even if the overload fault is restored unless this pushbutton is pressed.
R-Ph Auto/Manual & INC/DEC	Auto mode/Manual switch is for mode selection of R-Ph, INC switch for increase output voltage manually and DEC switch for decrease output voltage manually.
Y-Ph Auto/Manual & INC/DEC	Auto mode/Manual switch is for mode selection of Y-Ph, INC switch for increase output voltage manually and DEC switch for decrease output voltage manually.
B-Ph Auto/Manual & INC/DEC	Auto mode/Manual switch is for mode selection of B-Ph, INC switch for increase output voltage manually and DEC switch for decrease output voltage manually.



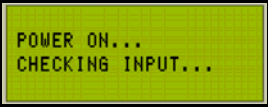
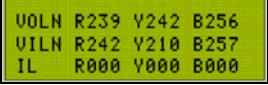
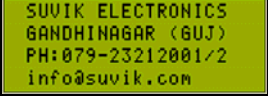

#### 4.2 PARAMETER DISPLAY

Display	Function
	When user power on the system that time 1st system will check Input voltage and regulate the output voltage if all voltage ok than start load.
	Parameter screen display the output voltage, input voltage and load current for R-Ph, Y-Ph and B-Ph.
	Display the Company name, Phone no, and Email for communication.

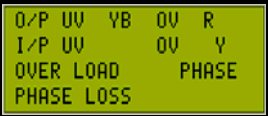
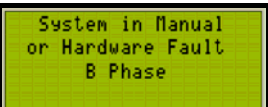
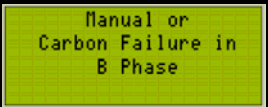
#### 4.3 FAULT DISPLAY

Fault	Function
	<p><b>O/P:</b> Output Voltage, <b>I/P:</b> Input Voltage, <b>UV:</b> Under Voltage, <b>OV:</b> Over Voltage.</p> <p>This screen will pop up When any fault occur</p> <p>1st line indicates output under voltage in Y-Ph and B-Ph and over voltage in R-Ph.            2nd line indicates for input over voltage in Y-Ph.            3rd line indication for Overload.            4th line for phase loss.</p> <p>When Fault occur TRIP indication on front Panel and Shut down the load and buzzer sound on if buzzer provision is there.</p>
	This warning message will pop up when System remains in manual or some hardware fault occurs.
	This warning message will pop up when carbon failed

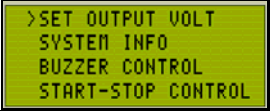
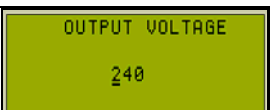
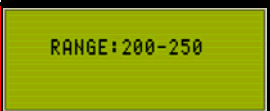
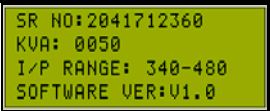
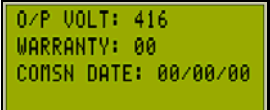
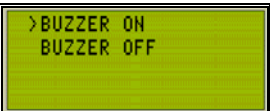
#### 4.4 USER PARAMETER CONFIGURATION

Parameters	Function
	Enter password 123 to change parameter.
	Configuration parameter for user.
 	<p>Selecting SET OUTPUT VOLT function this screen will pop up. Shift the cursor position right by SHIFT key and Increase digit value by INC key. To return back without storing data press ESC key and by pressing SET key user can set the output voltage.</p> <p>User can set the output voltage in the range of 200-250 voltage. System will automatically change output under voltage and overvoltage tripping thresholds by +/-10%. When user enters out of range voltage than other screen will pop up.</p>
 	<p>Selecting SYSTEM INFO 1st screen will pop up. SR No display the serial no of SCVR unit, KVA display the system KVA, I/P Range display system input operating range, Software version display the version of software used. By pressing shift key 2nd screen will pop up. O/P voltage display the current output voltage and warranty displays month of warranty and last commissioning date display the date of commission the system. To return from current screen press ESC key.</p>
	User can enable or disable buzzer (mute). Pressing BUZZER CONTROL parameter this screen will pop up. User can control BUZZER by selecting BUZZER ON / BUZZER OFF. Making BUZZER ON will mute the BUZZER even though fault is there.
 	<p>For enabling this feature factory setting is required. User can start and stop by selecting START/STOP. If fault is present and still user try to start system manually, 2nd screen will pop up.</p>

## 5.0 TROUBLE SHOOTING

There are six types of fault conditions being monitored and acted upon.

- Voltage faults – Under voltage (UV) and Over voltage (OV)
- Load Current fault - Overload
- Phase faults – Phase loss
- Phase Sequence fault.
- Carbon loss fault
- Manual or Hardware error.

Fault	Fault Description	Troubleshooting
<b>Voltage faults – Under voltage (UV) and Over voltage (OV)</b>	<p>Under voltage (UV) and Over voltage (OV) faults occur when the controlled output or input voltage goes beyond the range specified. When the input voltage varies beyond the range the stabilizer is not able to control the output within the specified regulation limits. The output or input voltage when crosses the UV or OV Trip voltage level, the display fault screen on the LCD Panel. Each of the three phases is individually monitored for all the faults. The occurrence of fault does not trip the output immediately. If the fault persists for no. of seconds specified then the output will trip. The red Trip LED will lit when the output trips.</p> <p>Similarly when the fault condition is removed (UV or OV) the tripped output does not come ON immediately. If the stable faultless condition prevails for no. of seconds specified, then only the output will come and the red Trip LED on the front of the controller box will go off.</p>	<p>If fault not remove than check the Input connection of system and load connection.</p> <p>If all connection OK than call CSD/Dealer for troubleshooting.</p>
<b>Overload fault:</b>	<p>Controller has default 20 second delay. If the Overload fault persists for 20 seconds then the output will trip. The red Trip LED will lit. The LCD panel starts displaying the OVERLOAD.</p> <p>When the fault overload condition is removed, the output will not restore automatically. The Overload Reset pushbutton (O/L RST) will have to be pressed manually to bring the output ON.</p>	<p>Check the load connection, if load connection Ok than check load is short circuit or not if short than remove short circuit and press O/L RST key from Front Panel of SCVR.</p> <p>If you pressed O/L RST key and still over load reset come than call CSD/Dealer for troubleshooting.</p>
<b>Phase Loss Fault:</b>	<p>This fault will occurs when any phase will get disconnected.</p>	<p>Check The Input connection and voltage at input terminal.</p> <p>Still you found same problem than call CSD/Dealer for troubleshooting.</p>

<p><b>Phase Sequence error:</b></p>	<p>This is an optional feature. This feature is useful for motor application. System will look for three phase in correct sequence.</p> <p>If user connects in wrong phase sequence than this error message pop up and system will remain in trip condition only.</p>	<p>Correct the phase sequence by change any two wire and restart.</p> <p>If user still found this error message than call CSD/Dealer for troubleshooting.</p>
<p><b>Carbon loss fault:</b></p>	<p>This error message indicates that carbon is breakdown in particular phase.</p>	<p>If user found this error message than user must have to call CSD/Dealer for troubleshooting.</p>
<p><b>Manual or Hardware error:</b></p>	<p>This message pops up when user place the SCVR system in Manual mode or any hardware fault will occur. System work healthy till Under/Over voltage come. When output voltage cross Under/Over voltage limits system will trip the load.</p>	<p>User must have to place the SCVR system in AUTO mode. After placing system in AUTO mode trip will come out and restart the load. After placing system in AUTO mode and error is still than call CSD/Dealer for troubleshooting.</p>

**6.0 CONNECTION**

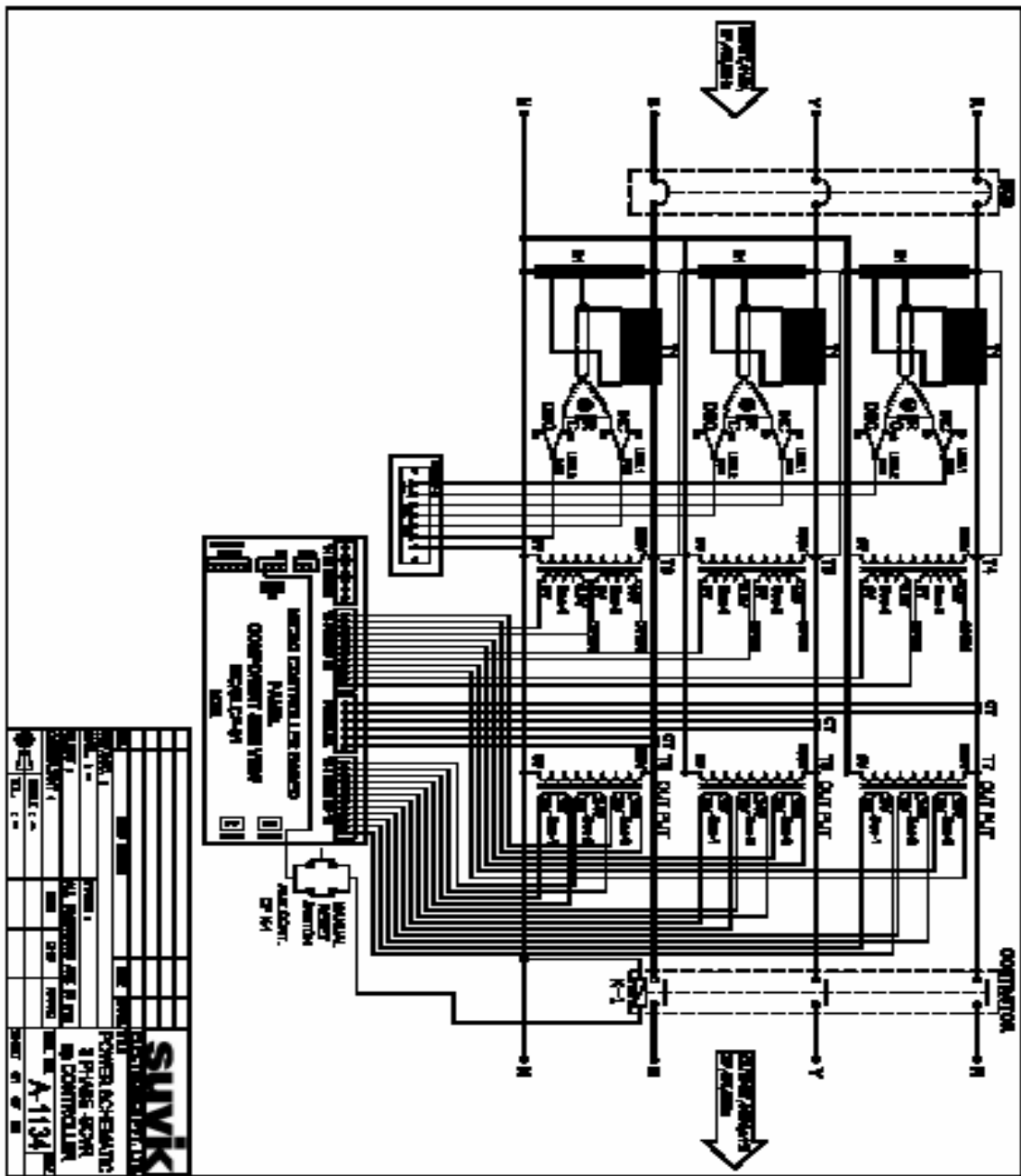

Fig-5

## **7.0 WARRANTY CERTIFICATE**

### **WARRANTY CERTIFICATE**

SUVIK products are manufactured to meet high standard of quality. This product is warranted against any manufacturing defect for a period of one year from the date of invoice/ purchase from Suvik or its authorized distributors, subject to the following conditions.

1. The defective unit will be replaced provided the unit is delivered to the Service Center at Customer's risk and cost. Any indirect or consequential loss to the purchaser / user is excluded from the warranty obligation of Suvik Electronics Pvt. Ltd. And its dealers / distributors.
2. The warranty is not valid in cases of damages resulting from
  - Accident, mishandling or negligence
  - Unauthorized modification and / or repair by the user
  - Operation outside the specification of the products.

This product has been tested and inspected as per specifications. In case of difficulty, contact your dealer/ distributors or

### **SUVIK ELECTRONICS PVT. LTD.**

Plot No. 102/A, GIDC Engineering Estate, Sector-28,  
Gandhinagar-3820028,(Gujarat), INDIA.

Tel.: +91-79-23212001, 23212002, 23212003 Customer  
Support: +91-79-2321 2005, Fax: +91-79-23212006,

Cable:"SUVIK" E-mail: [ser@suvik.com](mailto:ser@suvik.com) Website: [www.suvik.com](http://www.suvik.com)